

B

V

A

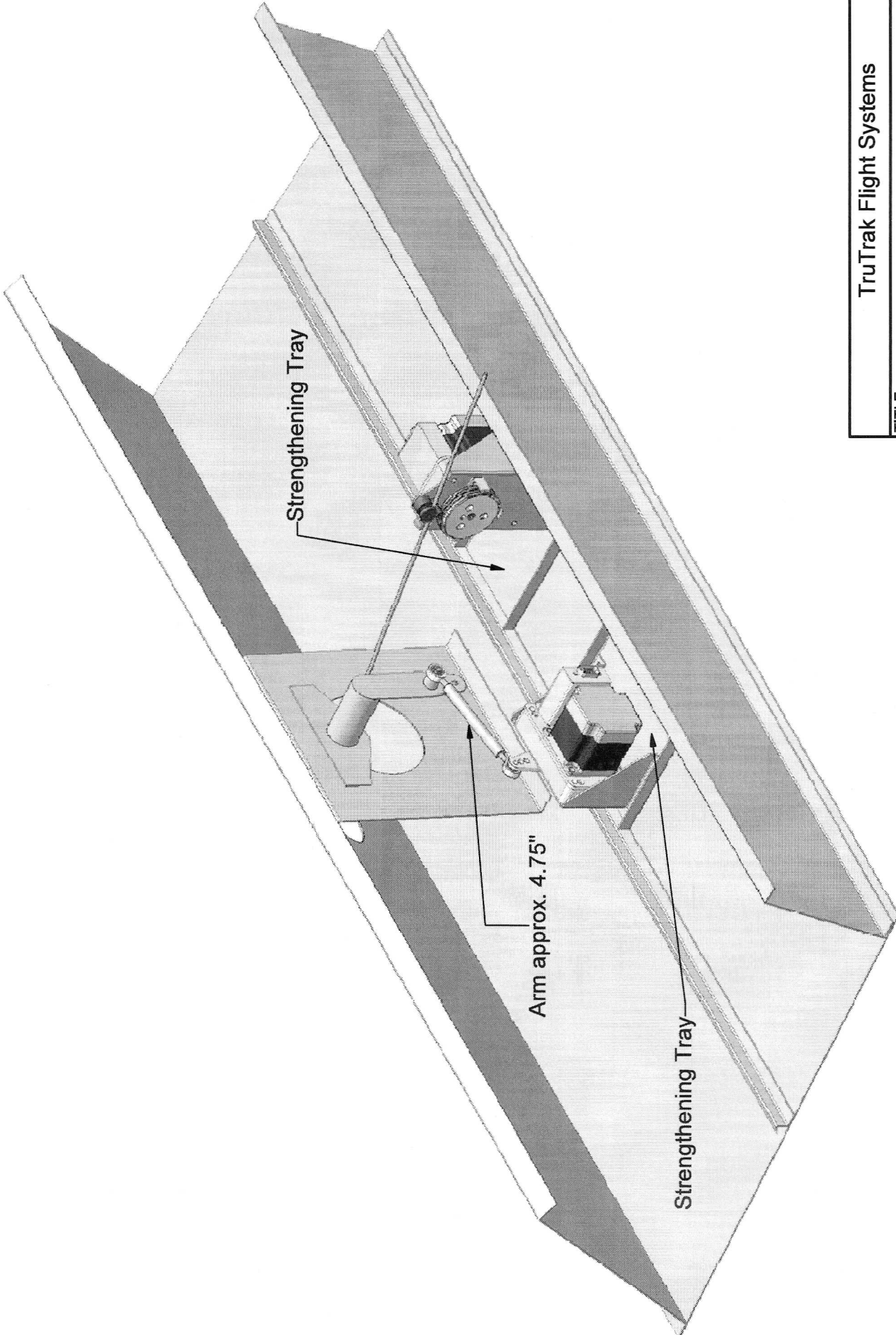

Strengthening Tray

Arm approx. 4.75"

Strengthening Tray

TruTrak Flight Systems

TITLE Zodiac Installation

| | | |
|----------|-----------------------|------|
| SIZE | DWG NO | REV |
| A | zodiac pitch and roll | |
| SCALE | SHEET | OF 3 |
| | 1 | 3 |
| DRAWN BY | | AHB |

1

2

B

V

A

2

1

B

B

V

V

A

A

2

1

1

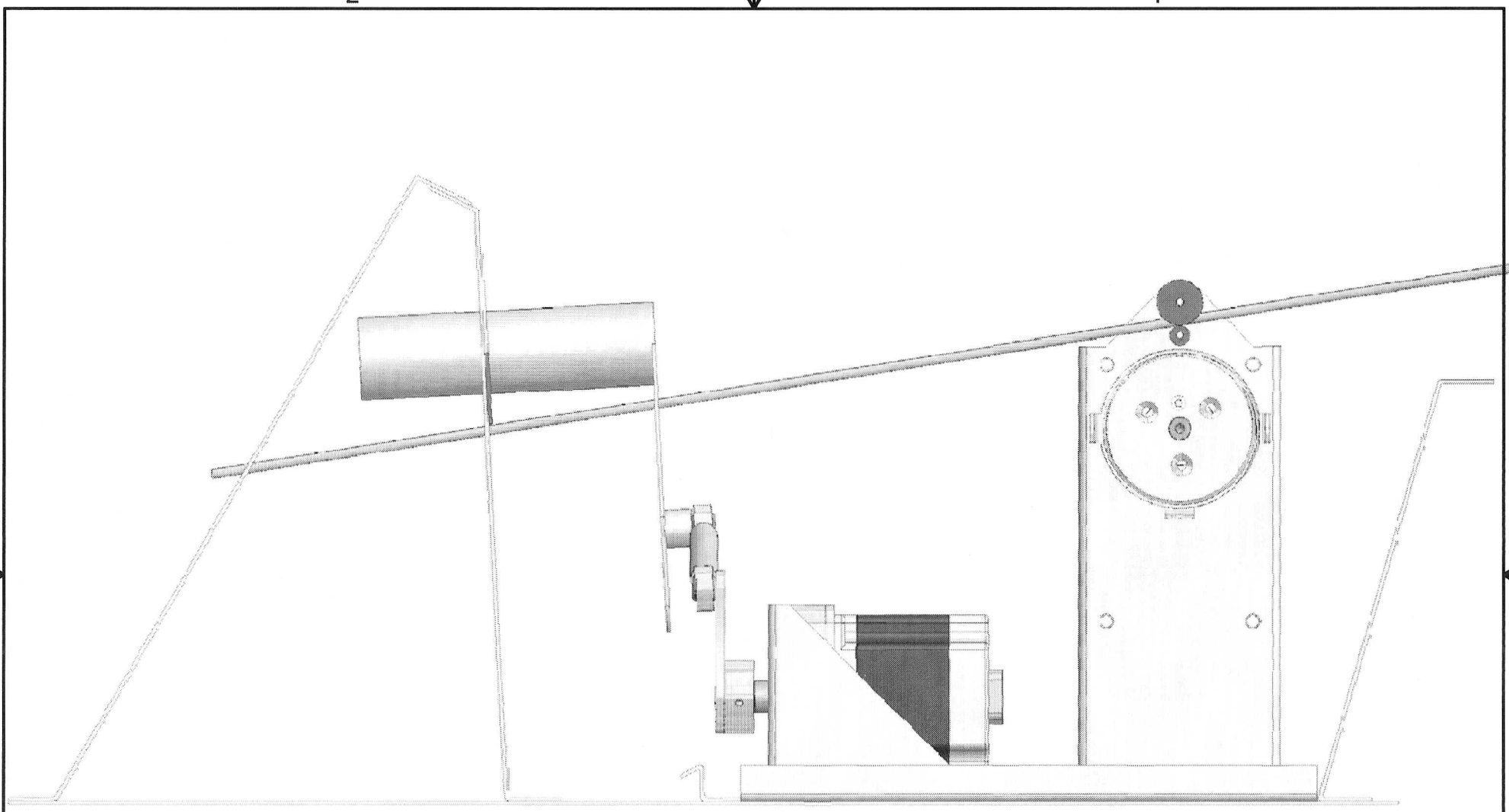

| | | | |
|-------------------------------|-----------------------|----------------------------|----------|
| TruTrak Flight Systems | | | |
| TITLE | | Zodiac Installation | |
| SIZE | DWG NO | REV | |
| A | zodiac pitch and roll | | |
| SCALE .5" = 1" | SHEET | 2 OF 3 | DRAWN BY |
| | | | AHB |

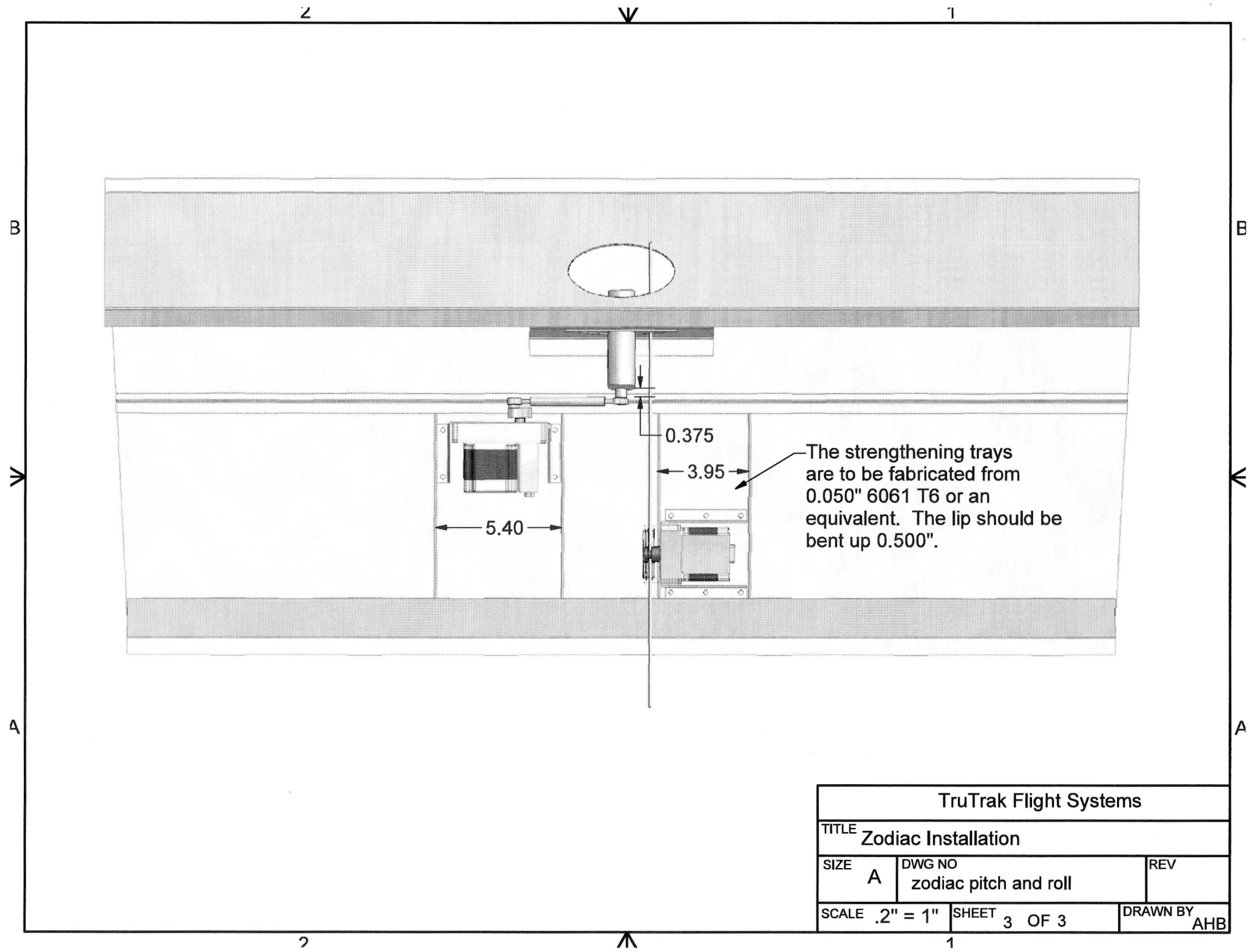

| | | |
|----------------------------------|---------------------------------|-----------------|
| TruTrak Flight Systems | | |
| TITLE Zodiac Installation | | |
| SIZE A | DWG NO zodiac pitch and roll | REV |
| SCALE .2" = 1" | SHEET 3 OF 3 | DRAWN BY AHB |